

KIT TE + HM 71 T4 2,2kW (A2:6) 35° (KTE71+26172462635P)

GENERAL DATA

AXIAL WITH FIBERGLASS COWL

MANUFACTURING FEATURES:

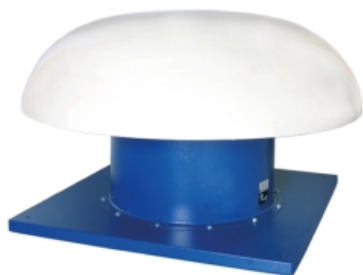

- Roof cowl made of reinforced fibreglass.
- Roof base support and bird protection guard with polyester powder coat finishing.
- Assembled on HM fans.(tubular)
- Variable pitch angle Polypropylene impeller (A2 profile) or polyamide impeller reinforced with fibreglass (other profiles).
- Squirrel cage asynchronous standard motor, IP-55 protection and rated class F insulation. Standard voltages 230V 50Hz for single phase motors, 230/400V 50Hz and for three phase motors up to 4kW and 400/690V 50Hz for higher powers.

APPLICATIONS:

Specially designed for roof installation, they are suitable for:

- Air renewal in buildings and industries.
- Smoke extraction.
- Maximum working temperature: 1ph 50°C, 3ph 60°C.

AVAILABLE ON REQUEST

- B form impeller (air flow from impeller to motor)
- Reversible impeller 100%
- Cast aluminium impellers.
- 60Hz fans and special voltages.
- 2 speed motors.
- Hot dip galvanised and stainless steel housings.
- Galvanised steel sheet cowl.

PERFORMANCE CURVE

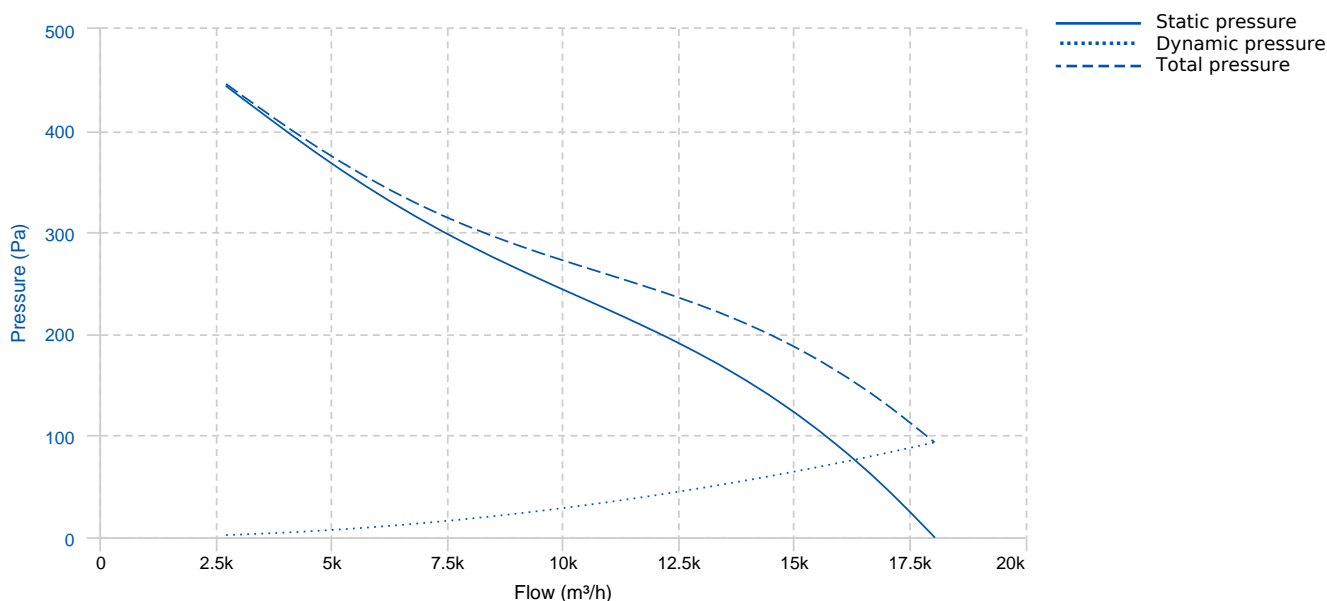

TECHNICAL DATA

Fan							
RPM	1435	Approx. weight	61 kg	Max. Flow	18030 m ³ /h		
Motor							
Power	2,2 kW	RPM	1435	I max. (230V)	8,07 A	I max. (400V)	4,64 A
Size	100L	Approx. weight	34 kg	Efficiency (%)	86.7 %	FP	0.81

DIMENSIONS

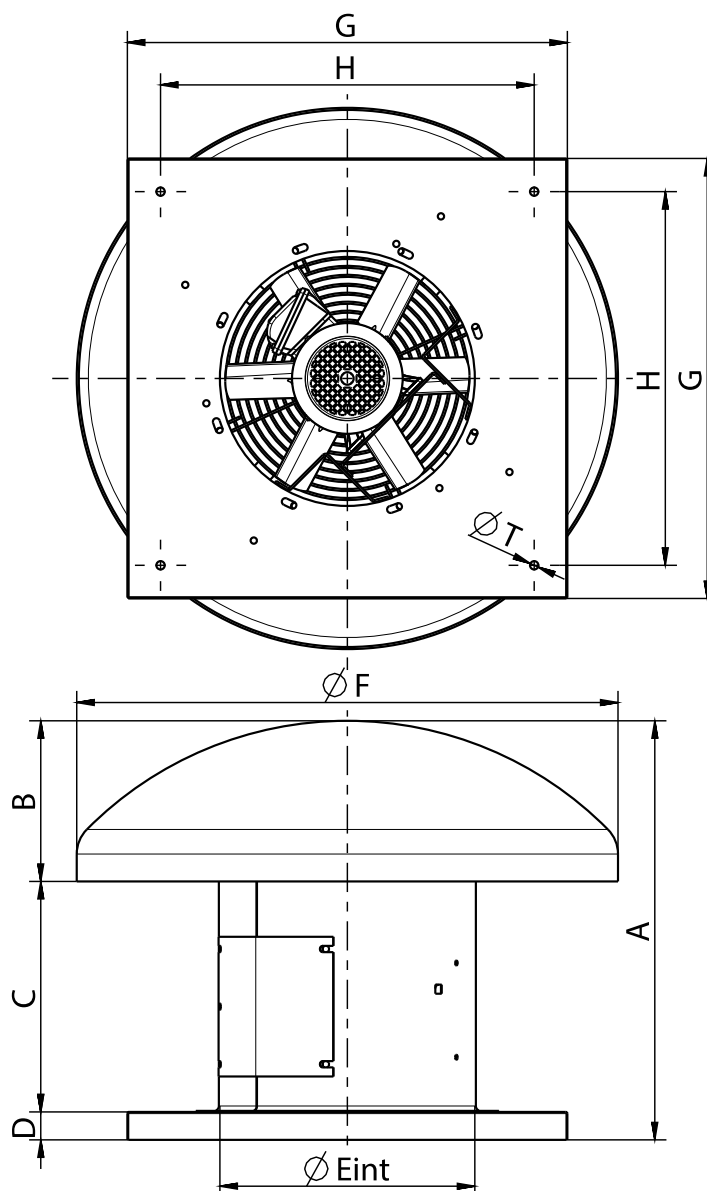

Dimensions (mm)									
A	1010	B	350	C	610	D	50	E	715
F	1290	G	1100	H	840	T	14		

WIRING DIAGRAM

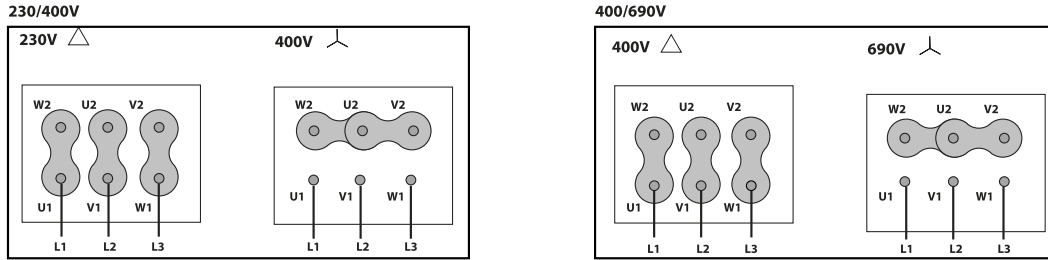

ACCESSORIES